

Low-Profile Pipe Dock

Assembly Instructions

RECOMMENDED TOOLS



Screwdriver
(#2, #3 Phillips)



Wrenches or sockets:
M10 (or 13/32")
M14 (or 9/16")
M15 (or 5/8")
M17 (or 11/16")
M18 (or 23/32")



Work Gloves



Rubber Mallet



Cordless Drill

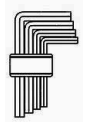

Allen Wrench
8mm (or 5/16")



Low-Profile Pipe Dock

Components

POTENTIAL DOCK COMPONENTS

Each dock order includes different components and quantities. Refer to your packing slip for all components and quantities. This chart represents common parts in Stationary and Rolling Pipe Docks.

	Part Number	Description
L	10835	LOW PROFILE FRAME KIT
A	10870/10851/10861/10957/10977	DECKING PANEL (CEDAR / GRAY POLY / TAN POLY / GRAY ALUM / BROWN ALUM)
F	10805	LOW PROFILE SPLICE TUBE
B	10886	DOCK BUMPER (Optional Accessory)
T	10937	LOW PROFILE POST BRACKET
D	10811	FOOT PLATE
E	10820	AXLE CONVERTERS (PAIR) (For Roll-in Docks Only)
W	10821	DOCK WHEEL (For Roll-in Docks Only)
I	10854	CORK ROLL (For Aluminum Decking Only)
AA	10867/10868	DECK LOCKERS FOR POLY / ALUMINUM DECKING

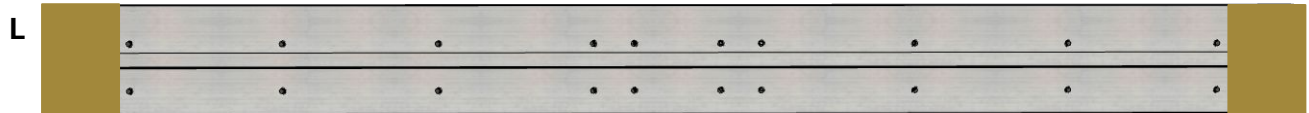

A

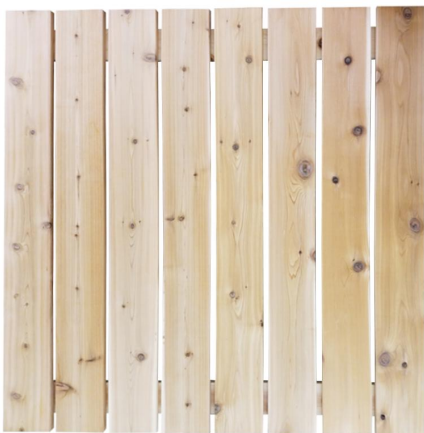

Cedar

Poly

Aluminum



F



B



W



T

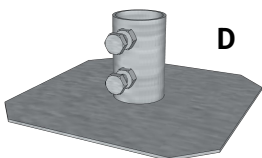

D

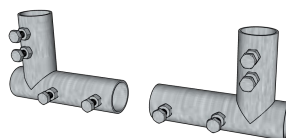

E



I



AA



Scan for Online Help:
FAQ, Online support



(651) 674-2450



info@patriotdocks.com

Low-Profile Pipe Dock

Components

A. EACH FRAME PACKAGE COMPONENTS			
	Part Number	Description	Qty
L1	10835-1	SIDE TUBE	2
L2	10835-2	CENTER TUBE	1
L3	10835-3	END TUBE	2
L4	10835-4	STRINGER TUBE	2
L5	10835-5	ANGLE 1	4
L6	10835-6	ANGLE 2	2
L7	10835-7	Gusset Bracket	4
L8	NA	FRAME ASSEMBLY HARDWARE KIT	1/each

PIPES			
Note: Aftermarket 1-1/2" ID Schedule 40 Galvanized Pipe can be added at any length if standard pipe sizes are not long enough.			
K	10812 10813 10814	4ft PIPE 6ft PIPE 8ft PIPE	

L8. LOW PROFILE Frame Hardware Kit			Qty
L8-a	M10X60 mm Flange Bolt		28
L8-b	M10 Nylock Nut		28
L11. Frame Connection (4" Bolt Kit L11)			
L11-a	4" Bolt		5
L10-b	Fender Washer		5
L10-c	M10 Nyloc Nut		5
Additional Hardware			
WW	Stop Clamp Pair (For Roll-in Docks Only)		1/wheel
WW2	Wheel Washer (For Roll-in Docks Only)		2/wheel
KK	Pipe Cap		1/pipe
BB Bumper Hardware Kit (Optional Accessory)			
BB1	Vinyl Bolts		4
BB2	Vinyl Nuts		4
BB3	Backer Plate		2

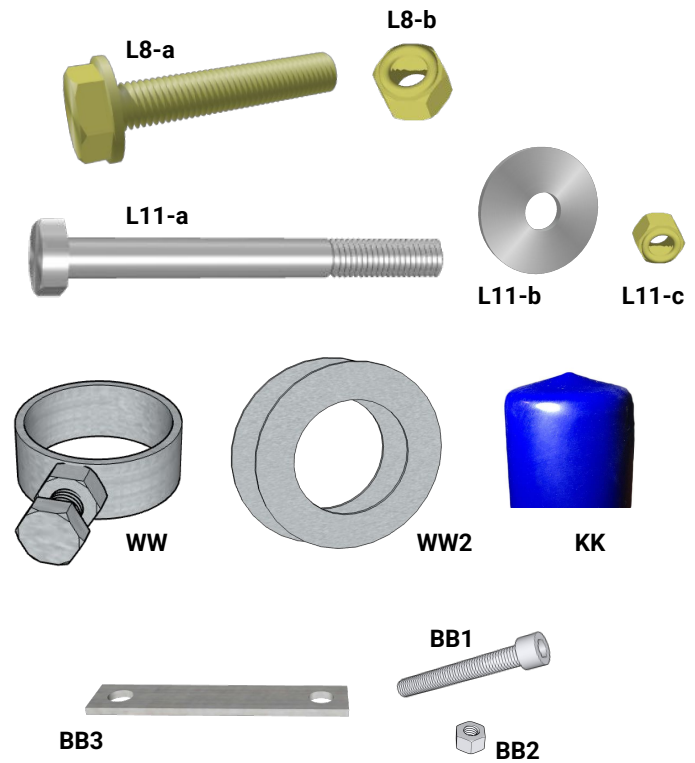
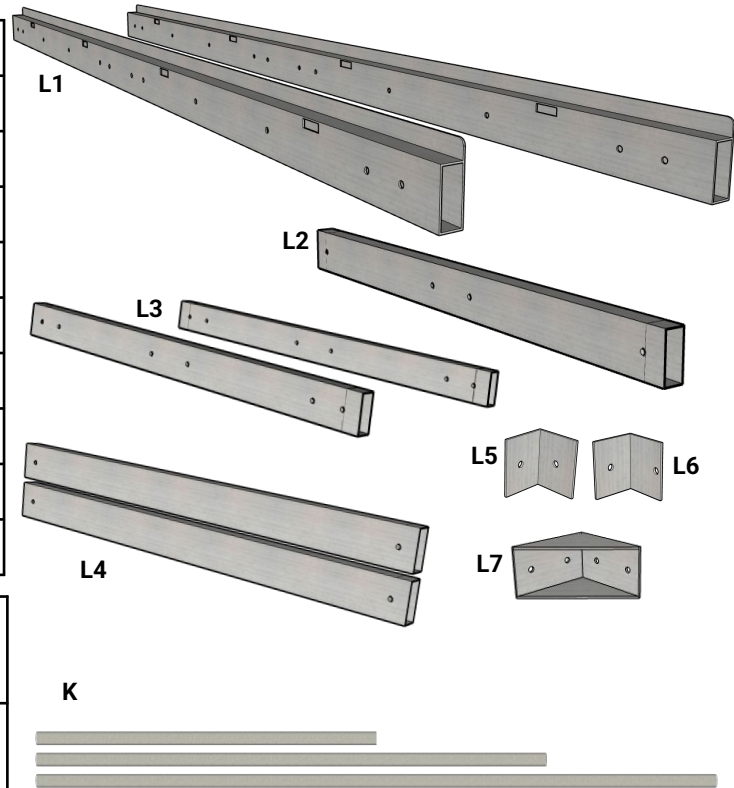

Low-Profile Pipe Dock

Assembly Instructions

- 1 Assemble the frame by laying out all parts of the first Frame Kit (L), making sure the End Tubes (L3) are oriented with the single-sided holes pointed inward. Assemble with M10x60mm bolts and Nyloc nuts (L8) as shown below. The hardware in the End Tube shared by the next frame will be replaced when joining the next frame assembly. Hand tighten. Set the frame aside.

EACH FRAME PACKAGE COMPONENTS			
	Part Number	Description	Qty
L1	10835-1	SIDE TUBE	2
L2	10835-2	CENTER TUBE	1
L3	10835-3	END TUBE	2
L4	10835-4	STRINGER TUBE	2
L5	10835-5	ANGLE 1	4
L6	10835-6	ANGLE 2	2
L7	10835-7	GUSSET BRACKET	4
L8	NA	FRAME ASSEMBLY HARDWARE	1/each

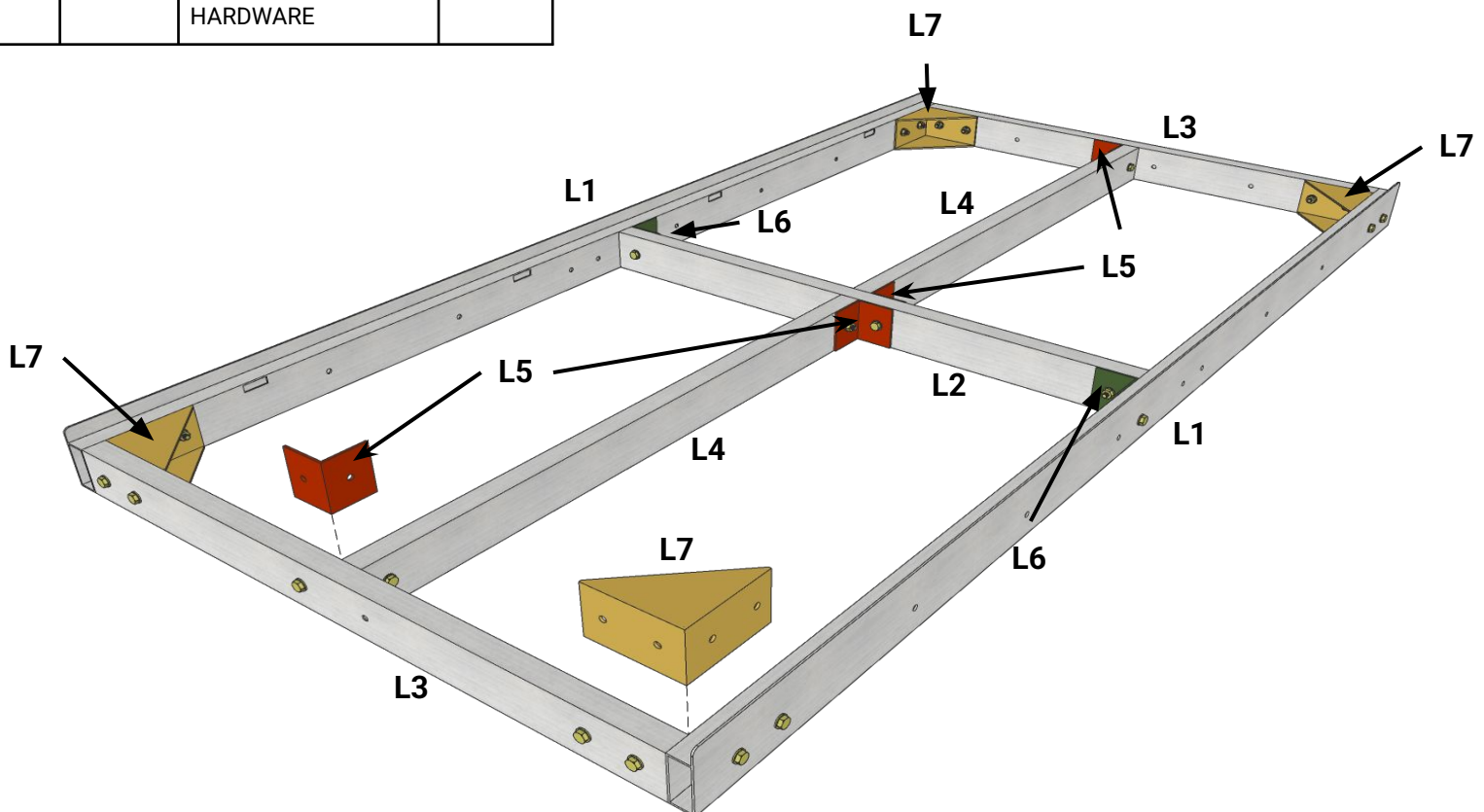
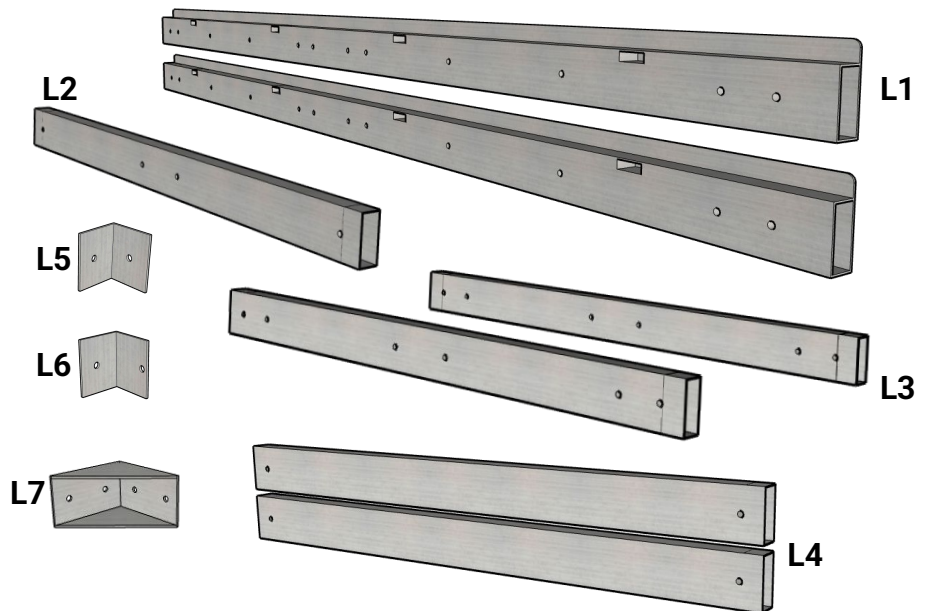

Low-Profile Pipe Dock

Assembly Instructions

- 2** Connect 4'x8' Frame sections using the Low Pro Splice Tube (S). The splice tube will insert inside the 8' Side Tubes (L1). Any bolts that are on the connecting ends of the 4'x8' frame sections will need to be removed before securing the splice tubes. Join frames together and secure splice tube using existing frame hardware.

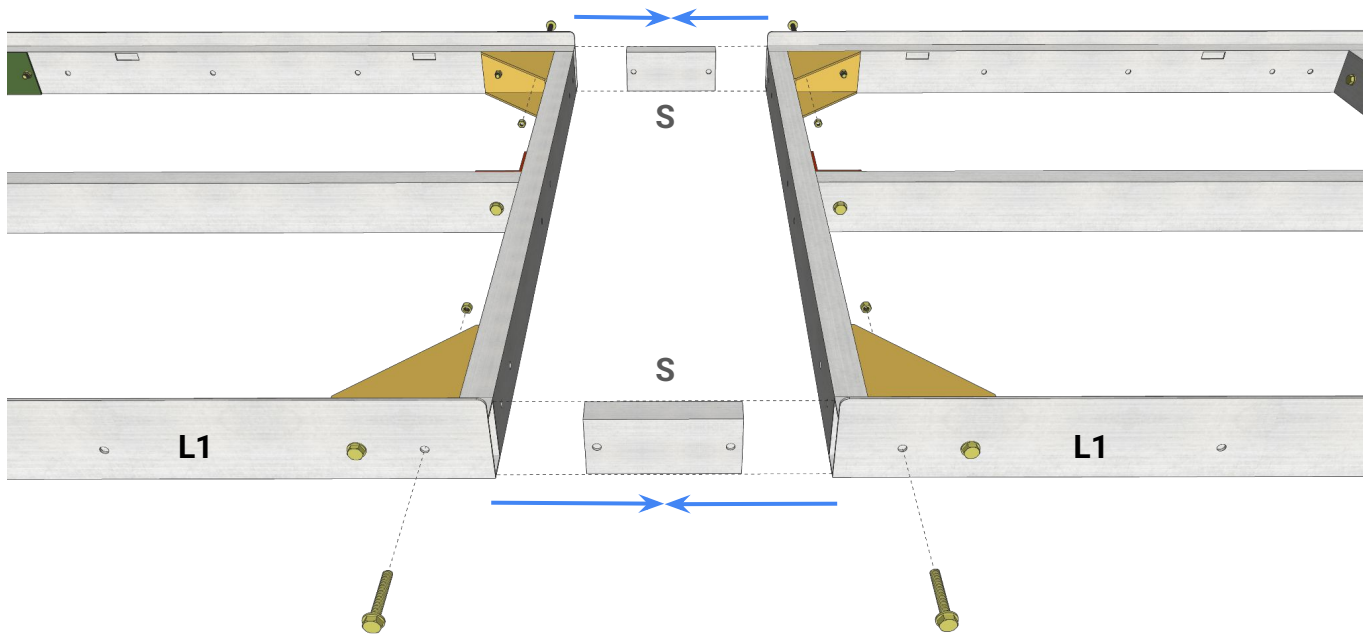

- 3** Use (5) 4" Bolts (L11) to join the two frames together. Make certain the fender washers are on either side of the frame tube. The 4" bolts replace the M10x60mm frame hardware in two locations.

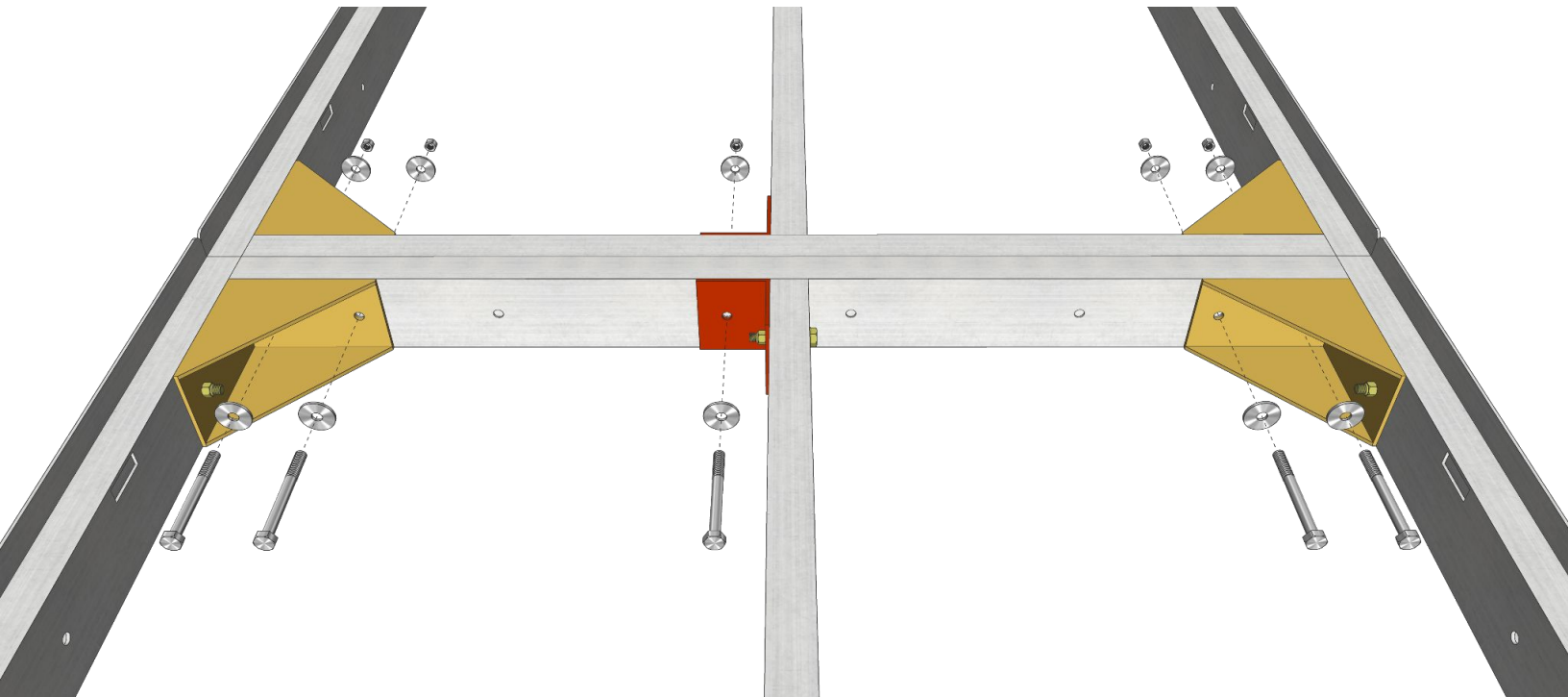

- 4** Assemble any optional patio frames (extending left or right) as a bolted side-to-side connection with (2) Frame Kits (L) and (1) 4" Bolt Kit (L11). This may require removal of frame hardware in the main stretch of dock. Use (5) 4" bolts (L11) on both ends of frame unit and on one sides of center tube. Loosely tighten the nyloc nut.

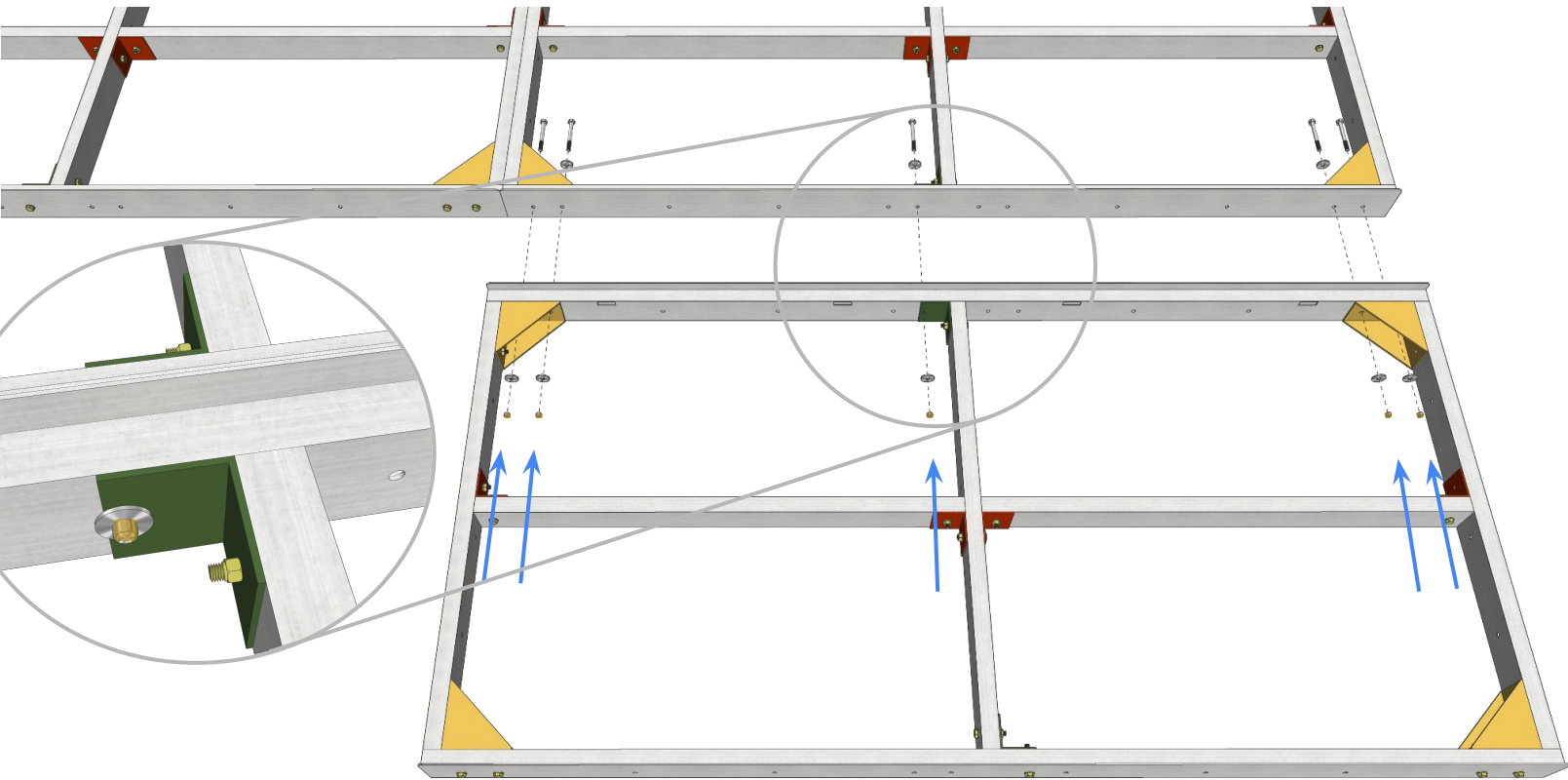

- 5a** Once Frames are all connected with hardware still loose, mount each Low Profile Post Brackets (T). Low Profile Pipe Docks **require a support every 8 feet when installing a straight dock, and every 4 feet when installing a Patio section.** See next page for more information on support placement for patio docks. There are multiple mounting points on each 8' Side Rail (L1). The shore end of the first frame will rest on the shoreline, mount to the first set of support brackets at the lake end of that frame, and every 8' thereafter. Use either existing frame hardware when mounting or included extra M10x60mm bolts/nuts to mount the Low Profile Post Bracket in place. Once all brackets are installed, firmly tighten ALL frame and support hardware.



Low-Profile Pipe Dock

Assembly Instructions

- 5b** When building a patio shape, support every 4 feet. Low Profile Post Brackets (T) can mount on the left or right side of the 4' End Tube (L3). Mount them near frame connections. Extra Supports are recommended in high traffic areas.

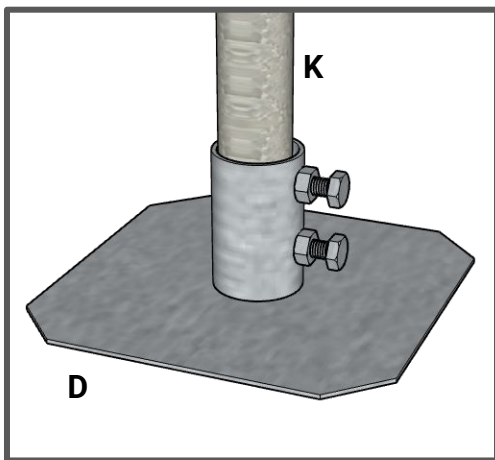

- 6** Attach Foot Plate (D) by inserting Support Pipe (K) into Low Profile Post Bracket (T). Connect Foot Plate (D) to the bottom of the Support Pipe. Tighten pinch bolts down to secure Foot Plate to Pipe. If adding Axle Converters see step 7.



Low-Profile Pipe Dock

Assembly Instructions

- 7** For Roll-in packages connect Axle Converters (G) to the bottoms of the Support Pipe (K). Orient Axles to face inwards towards the center of the dock frame. Using included axle pipe, string pipe through both Axle Converters. Mount the Dock Wheel (H) with a Wheel Washer (EE) on both sides of the wheel. Secure wheel with Stop Clamp (DD).

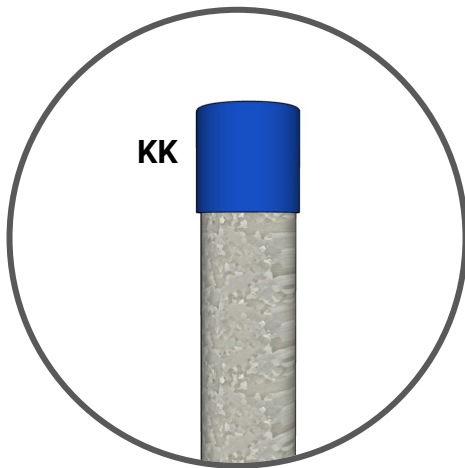
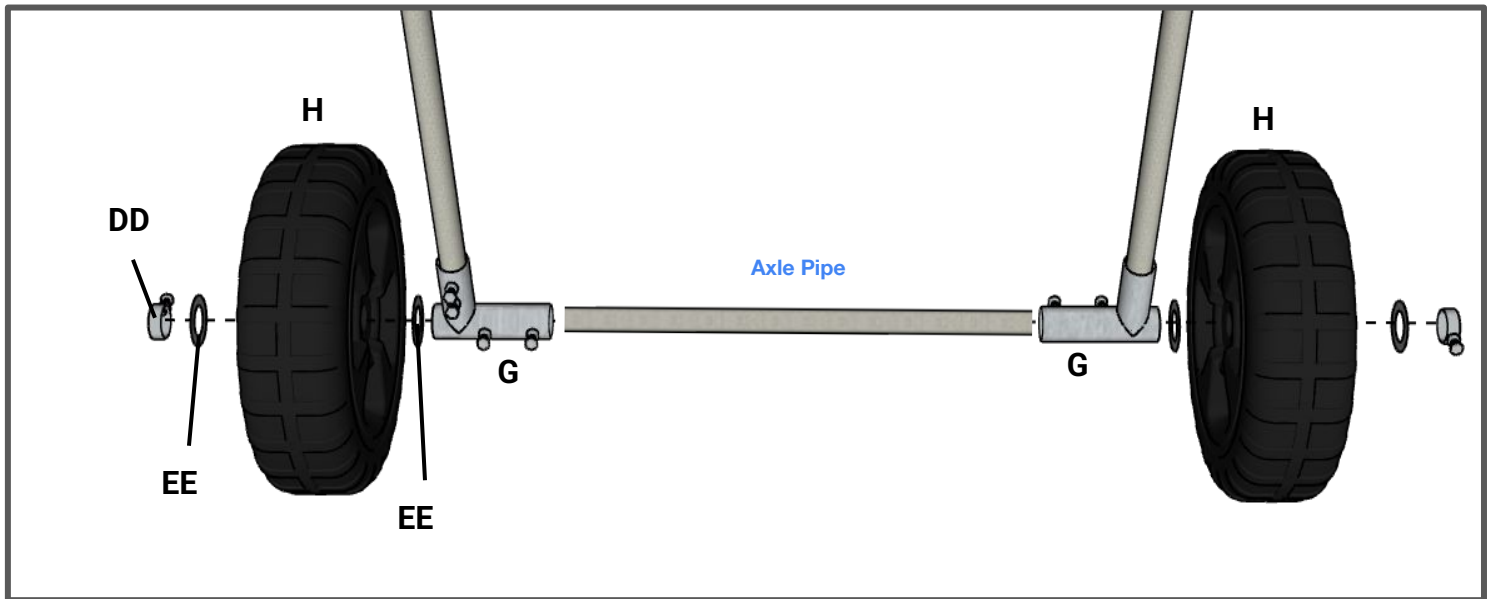

- 8** Next, find your desired height on your support. Raise the dock to the desired height, and tighten pinch bolts on Low Pro Post Bracket to secure your dock. Once all supports are set attach Post Cap (KK) to the tops of all support post.

- 9** Connect Dock Bumpers (B), to desired supports as an optional accessory. Notice on the inside of the bumper it is molded to slip fit onto the Low Profile Post Bracket (T). Orientate bumper so it fully encloses post bracket. Use included Bumper Hardware to secure. Backer Plate (BB3) will pinch the bumper to the post bracket. Image shows inside of Bumper mounted to Post Bracket.

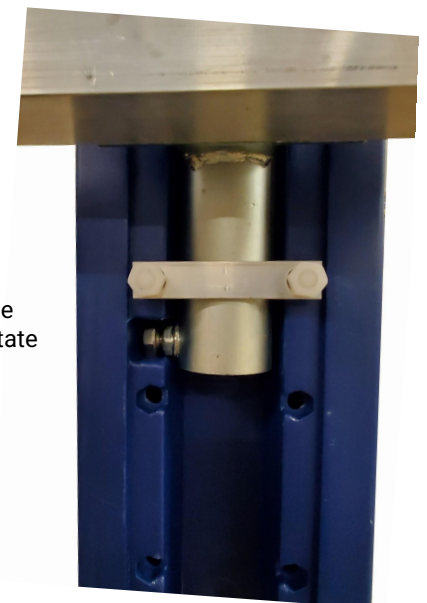

Low-Profile Pipe Dock

Assembly Instructions



Cedar Panels (A)

Cedar Panels are pre-assembled. At this point, panels can be sealed with deck sealer or stain for longest life (optional). Oil-based sealers work well and come recommended for protection against sun and water damage on cedar decks.

Assemble Poly 4x4 Decking Panel (A)

Poly Panels are assembled by screwing the stringer to the back of (4) 1'x4' boards. The stringer is screwed to the panels 11-3/4" from the outside edge of the panels using (8) M5x25mm panhead screws. Poly Deck Lockers can then be mounted to the board gaps near each of the 4 corners of the 4x4 panel. Use (2) screws provided in the deck locker package to screw the locker so the tab is facing the outside of the panel and the shaft is in between the boards.

Poly Decking		
Part Number	Description	Quantity
PN10850	1'x4' Gray Poly Boards	4
PN10860	1'x4' Tan Poly Boards	4
PN10851-2/61-2	Poly Stringer	2
	M5x25 Pan Head Screw	16

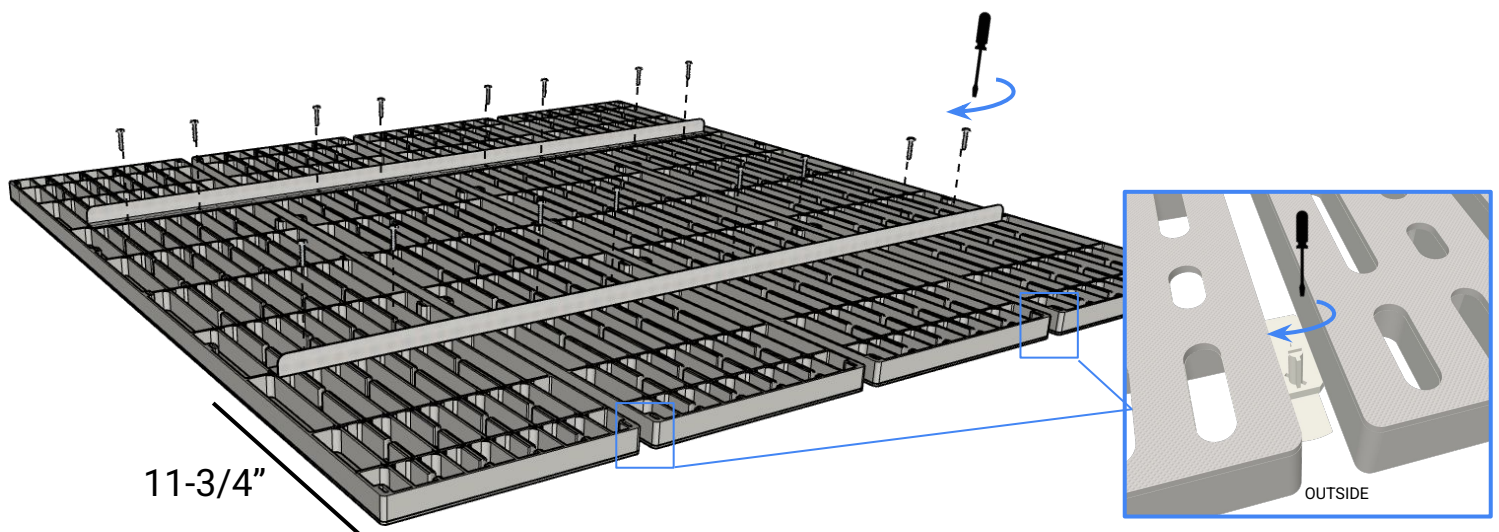

To lock your poly panel to the frame after installation, lay the decking panel on the frame, press the panel down firmly, then turn the shaft protruding through the boards until the locker tab is positioned under the frame.



Low-Profile Pipe Dock

Assembly Instructions

Assemble Poly 4x4 Decking Panel (A)

Aluminum Panels are assembled by attaching the stringer to the back of (8) boards. The stringer slides on the boards so that the stringer clips accept the bottom tongue of each board tightly. A rubber mallet may help to tap the stringer into place so that it is positioned about 11" from the outside edge of the panel. Once in position, the (16) set bolts in the stringer assembly tighten down onto the panel. Do not overtighten or strip the bolt heads by tightening quickly. This is best done with a screwdriver by hand. Aluminum Deck Lockers (AA) can then be mounted to the board gaps near each of the 4 corners of the 4x4 panel. Tap the locker onto the panel and slide it 1-1/2" from the edge of the board. Use (1) screw provided in the deck locker package to screw the locker so the tab is facing the outside of the panel and the shaft is in between the boards.

Aluminum Decking Components

Aluminum Decking Components		
PN10977	Brown Aluminum Boards	8
PN10967	Gray Aluminum Boards	8
PN10950	Aluminum Stringer Assembly	2

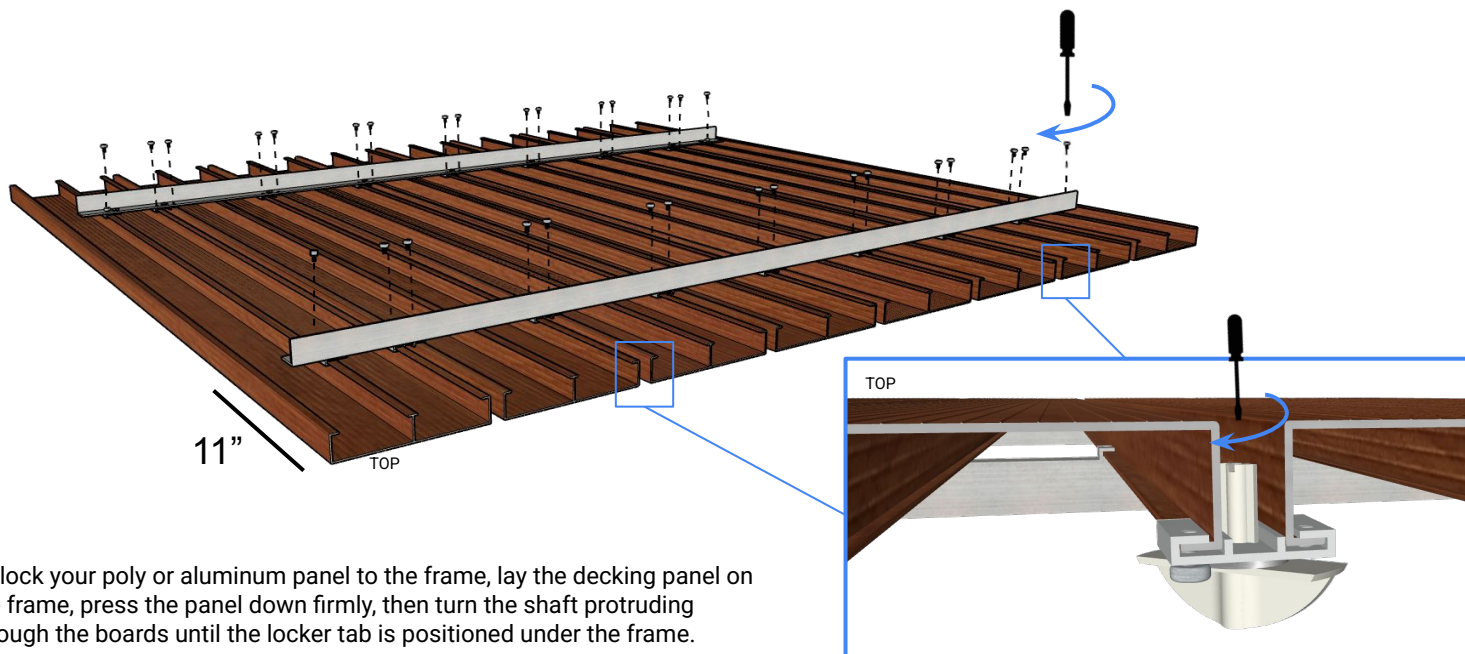
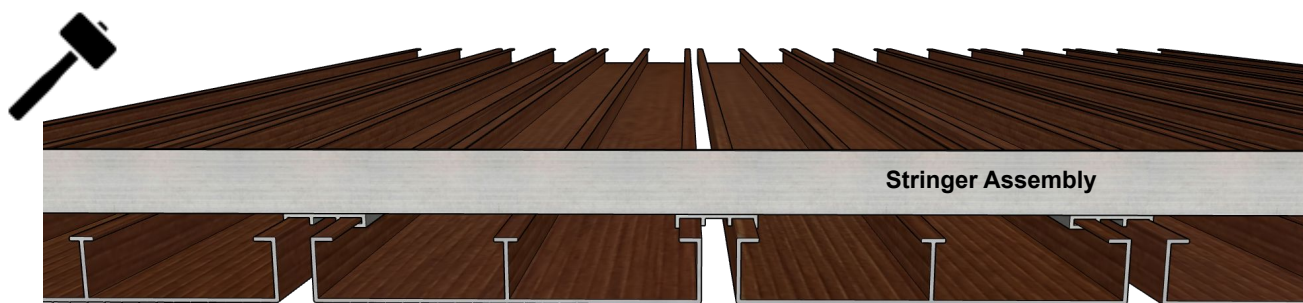

To lock your poly or aluminum panel to the frame, lay the decking panel on the frame, press the panel down firmly, then turn the shaft protruding through the boards until the locker tab is positioned under the frame.

